

## Reclaimer

### Industry

Coal export terminal

### Application

1-on-1 Reclaimer transfer designed to reclaim material and deliver to fixed conveyor

### Material

Product Coal

### Objective

As a part of expansion, the customer required a new reclaim transfer chute system to be installed on a new reclaim machine

### Transfer Detail

1-on-1 transfer chute system with inlet hood, lower fines chute, and outlet skirts on 1800 mm and 1600 mm conveyors. Inlet hood is fixed to slew ring, while other components are fixed to portal frame.

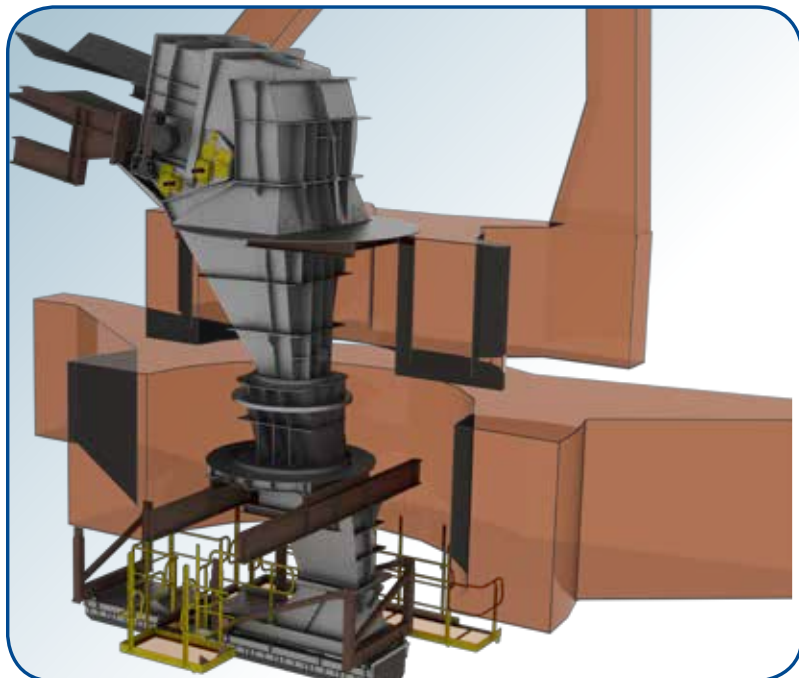

### Challenge

As part of a terminal capacity upgrade/expansion, a design was requested for a reclaimer transfer chute system with boom arm pivoting up and down and, at the same time, slewing around the vertical axis. The 2000mm wide feed conveyor runs at 4.2m/s and the 1600mm wide receiving conveyor at 6.1m/s.



### Flexco Solution

Flexco designed a complete reclaim transfer chute system that maintains control of the material flow through the full range of luffing (11° up and 9.5° down) and rotating actions around the vertical slew axis of the boom conveyor. All joints are sealed to minimize airborne dust and spillage.

When transferring material to the fixed conveyor, the material is launched from the feed conveyor, collected and controlled, then soft loaded onto the receiving conveyor. Skirts and chutes are then designed to accommodate emergency stop conditions and potential spillage of coal.

### Result

The customer now has a new transfer system with the ability to sustain good production at any defined boom arm position and minimum environmental impact including dust, noise, and spillage.

10351 Rising Court • Woodridge, IL 60517 U.S.A.  
Tel: 1-815-609-7025 • Fax: 1-815-609-0566

Visit [www.flexco.com](http://www.flexco.com) for other Flexco locations and products.